

Copilot Pro[®]: A full method for the steering of the machining

É. Pairel^{1,*}, E. Goldschmidt², B. Vayre¹, P.-A. Adragna³, and M. Pillet¹

¹ Université de Savoie, Polytech Annecy-Chambéry, Symme lab., BP 80439, 74944 Annecy Cedex, France

² Centre Technique des industries du Décolletage (Ctdec), 750 avenue de Colomby, BP 65, 74301 Cluses, Cedex, France

³ Université de Technologie de Troyes, LASMIS lab., 12 rue Marie Curie, 10010 Troyes, France

Received: 15 February 2011 / Accepted: Accepted: 17 March 2011

Abstract. Copilot Pro[®] is a method for the initial and regular machine-tools setup, developed by the SYMME laboratory of the Savoy University and by the Technical Center of Industries of Screw-machining (CTDEC) in France. Its first step is the organization of the different machining operations, in setup steps, themselves subdivided into measuring steps. The second step consists in determining the manufacturing dimensions to measure at the end of each measuring step. Finally, the third step consists in linking the manufacturing dimensions to both the correctors and the tool-dimensions, in the aim of calculating the corrections that have to be done in function of the deviations measured on the manufacturing dimensions. With this method, the steering of an industrial workpiece is performed with two steering parts instead of ten before.

Keywords: Setup; machining; tolerancing; process plan; Copilot Pro[®]

1 Introduction

This paper presents the Copilot Pro[®] method, developed by the SYMME laboratory of the Savoy University and the Technical Center of the Industries of Screw-machining (CTDEC) in France [1].

This method gives a full, quick and reliable tool setup procedure for the machines, in function of the geometric deviations recorded on the workpieces.

This method is operational, at the present time, only for the distances between the geometric features of a part, along the three directions of the space (the angular deviations are not considered yet).

This method is very innovating because, until now, no academic method has had proposed organizing machining operations in order to minimize the interruptions needed for measuring the workpiece, neither to directly link the measured dimension deviations to the correctors and shape tools dimensions.

We will present the method on an industrial process example of the screw-machining of a revolute part (Sect. 2).

The application of the Copilot Pro[®] method on this process and its experimentation are presented in Sections 3 and 4. It permits dividing by five the time and the number of workpieces needed for the initial setup of the tools.

The use over time of the setup plan and the monitoring plan, introduced by the method, is briefly explained in

Conclusion and the development outlooks of this method are presented in Section 4.

2 Presentation of the industrial part and process

The part has five finished surfaces (numbered 1 through 5 at the bottom of Fig. 1) and four rough surfaces (numbered 2a, 3a, 4a and 5a).

The finished surfaces are located by four design dimensions (indicated above the drawing of the part in Fig. 1), and the rough surfaces, by four stock removal dimensions (indicated below the drawing of the part in Fig. 1).

The part is machined out of a bar by a set of thirteen tools (Fig. 2).

The manufacturing process begins with the translation of the bar until the front surface touches the retractable stop which makes surface 5a. Most of the machining is done with the bar pinched by the chuck of the main spindle. Only the rear chamfers (on the left side of the part in Fig. 2) are machined on the secondary spindle after the part has been sawed off.

Eight tools machine flat surfaces, either roughed or finished on the part, counting the retractable stop as an adjustable tool (they are shaded gray in Fig. 2). The others machine either cylinders or cones and do not present any adjustment difficulties.

To adjust this subset of eight tools, we must determine a set of measurable manufacturing dimensions between the different flat surfaces of the part.

* Correspondence: eric.pairel@univ-savoie.fr

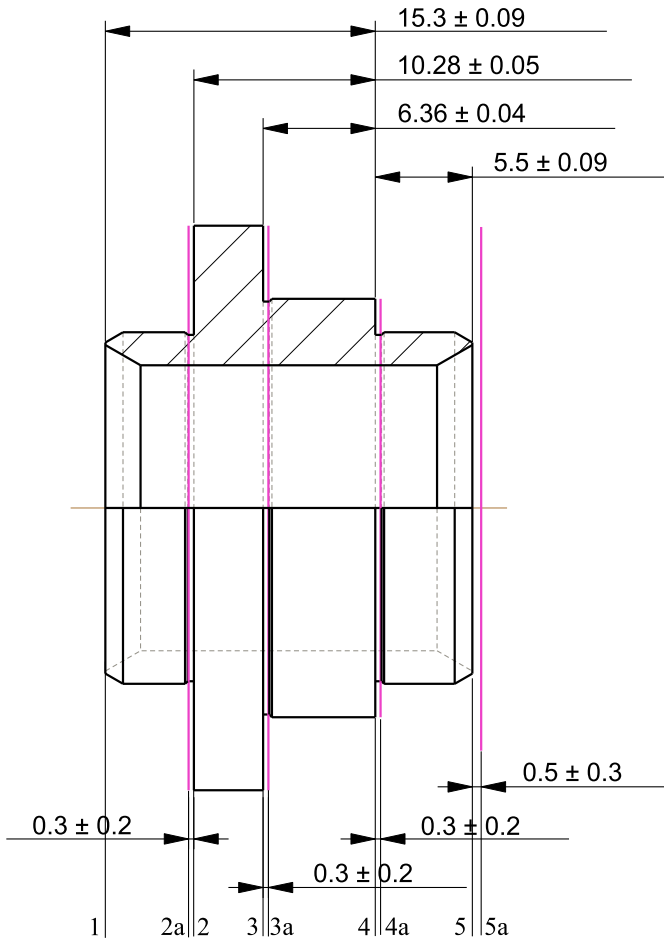

Fig. 1. The industrial part with four design dimensions and four stock removal dimensions.

Currently, no manufacturing dimension set is established prior to the setting up of the machine. This task is left to the operator who chooses herself/himself a set of dimensions while being in front of the stopped machine. Usually the operator chooses “Wade dimensions” [2, 3], i.e. dimensions allowing her/him to adjust independently each tool by the measurement of a single dimension on the part.

So, on this part, the operator would measure the dimensions between each machined surface and surface 1, performed by the sawing off of the part needed to be able to remove it from the machine for measuring (this is the most common method used in the screw machining industry).

In order to simplify more, he often adjusts individually each tool and saws off a new workpiece for each one of them, even though he could group several machining operation before sawing off the part.

Thus, for the workpiece, requiring thirteen tools, the operator has manufactured about the same number of parts for the initial setup of the machine.

In addition to material consumption, this method leads to long setup times and therefore to productivity losses.

Furthermore, the manufacturing dimensions that he measures being very different from the design dimensions, the operator also measures the latter to ensure herself/himself of the conformity of the workpieces.

Tolerances on these manufacturing dimensions could help avoid measuring the design dimensions, but, on the other hand, they could lead to scrap conform workpieces in regard to the design dimension tolerances, and this, amplified by the fact that these tolerances are much smaller than the design dimension tolerances.

3 Steps of the Copilot Pro[®] method

3.1 First step: setup plan determination

The first step of the Copilot Pro[®] method, called “the generation of the setup plan”, consists in grouping the manufacturing operations in setup steps, themselves subdivided into measuring steps.

A setup step groups all the manufacturing operations which can be setup simultaneously and between which there is no stock even if they are made in different workpiece carriers, on different machines.

For our example, all of the manufacturing operations performed on the main spindle (first workpiece carrier) and the opposite spindle (second workpiece carrier) can be grouped in the same setup step. This means that it is possible to wait for the end of all the operations before adjusting all the tools simultaneously.

A setup step often has to be divided into several measuring steps. A measuring step consists in grouping several manufacturing operations which have been verified through measurement before the execution of other manufacturing operations.

Several constraints can lead to subdivide a setup step into several measuring steps. The most frequent one is the need of measuring the positions of rough surfaces before they disappear with the finishing operations. We can also have temporal constraints between two manufacturing operations for technological reasons.

For the industrial part, taken in example, the single setup step has to be divided into two measuring steps. The first one will contain all the roughing operations with the sawing off operation in the aim to measure, outside of the machine, the distances between surfaces 1, 2a, 3a, 4a and 5a. The second measuring step will contain the finishing operations making surfaces 1, 2, 3, 4 and 5.

Each measuring step has to contain, at least, one surface of known position, which was also known in the previous measuring step. This is the requirement to be able to transpose the design and stock removal dimensions into manufacturing dimensions.

In this example, surface 1 is common to both measuring steps because it is made for each of them and is therefore of known position in each of them.

All the setup steps, subdivided into measuring steps, constitute the “setup plan” as we call it.

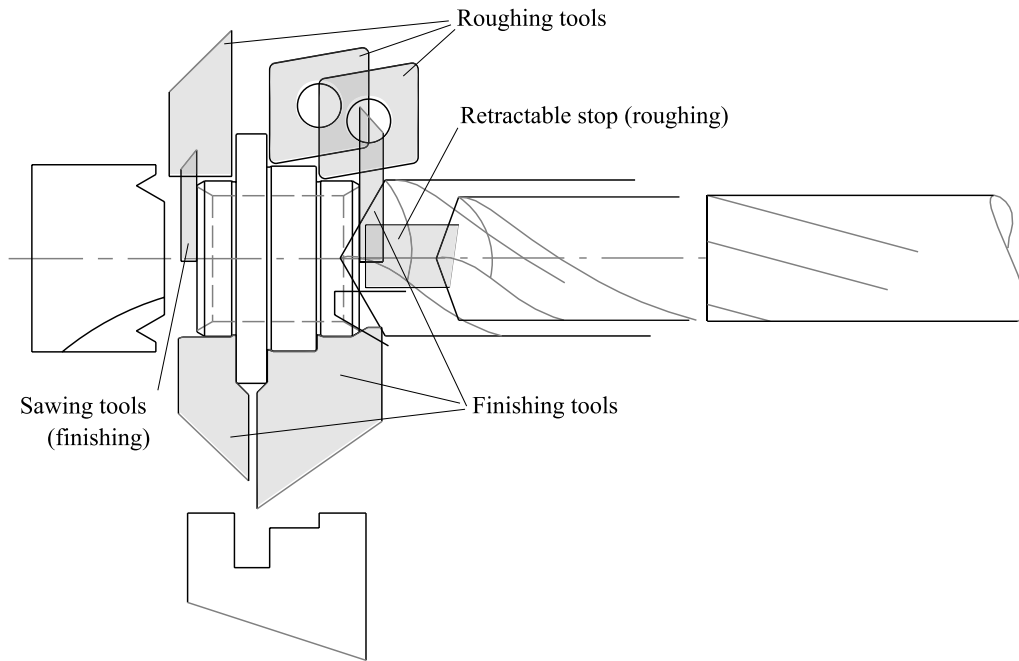

Fig. 2. The thirteen tools used for manufacturing the part.

3.2 Second step: manufacturing dimensions determination

Once the setup plan established, the second step of the Copilot Pro[®] method consists in determining the manufacturing dimensions that need to be measured at the end of each measuring step.

The method used here is the one introduced by Bourdet in the seventies [4, 5]: for each design or stock removal dimension, a minimal chain of manufacturing dimensions is sought for among the entire potential manufacturing dimensions.

The potential manufacturing dimensions are the ones which can be measured between two surfaces out of the five performed in the first measuring step, 1, 1, 2a, 3a, 4a and 5a, and between two surfaces out of the five performed at the second measuring step, 1, 2, 3, 4 and 5.

Thus, in our example, one manufacturing dimension of the second measuring step corresponds directly to each design dimension, and two manufacturing dimensions correspond to each stock removal dimension: the first one in the first measuring step and the second one in the second measuring step. For instance, the stock removal dimension CM3-3a will be measured indirectly by CF1-3a, at the end of the first measuring step, and by CF1-3, at the end of the second measuring step.

In total we obtain four manufacturing dimensions for the first measuring step and eight manufacturing dimensions for the second measuring step (four corresponding directly to the design dimensions and four more coming from the stock removal dimensions).

These last eight manufacturing dimensions are overabundant for positioning the five surfaces performed in the second step. Four would be enough.

It would be possible, for example, to choose the ones which are easier to measure, but we think it is better to keep, in priority, the manufacturing dimensions corresponding directly to the design dimensions [6]. Thus, the manufacturing dimensions will be useful for the tool setup (Sect. 3.3) and for the conformity verification of the parts. In addition, this enables us to obtain greater tolerances on the manufacturing dimensions (in the condition, however, that the tolerances of the stock removal dimensions are greater than the ones of the design dimensions).

Figure 3 shows the manufacturing dimensions selected for the first measuring step (on the top of the drawing) and the ones for the second measuring step (at the bottom of the drawing).

By privileging the tolerances of the manufacturing dimensions which correspond directly to the design dimensions (second part of Tab. 1), we can assign them the entire amount of the tolerance of the design dimensions (Tab. 1 and Fig. 1).

This set of manufacturing dimensions, being optimal from a tolerance and part acceptance point of view, is not sufficient for the setup of tools because the relationships between these dimensions and the positions of the tools are much too complex for the setter.

We will supplement it with a set of “pilot dimensions” which will represent the positions of the tools and the shape tool dimensions, and with relationships from one set to the other one (Sect. 3.3).

3.3 Third step: determination of the pilot dimensions and their relationship with the manufacturing dimensions

The third and last step of the Copilot Pro[®] method consists in calculating the relationships between the

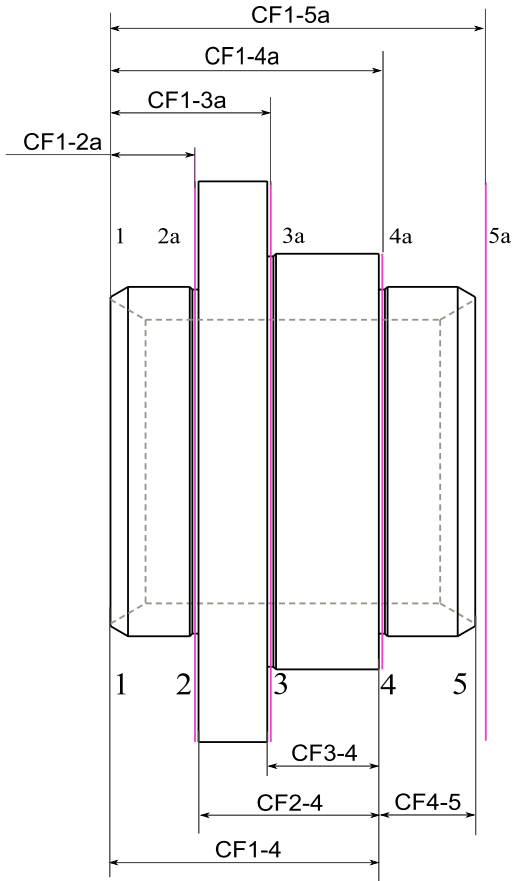

Fig. 3. Selected manufacturing dimensions for the first measuring step (on the top) and for the second step (at the bottom) of setup plan.

Table 1. Best tolerances for the selected manufacturing dimensions.

	Target	Tolerance
CF1-2a	4.72	±0.06
CF1-3a	9.24	±0.07
CF1-4a	15.60	±0.11
CF1-5a	21.30	±0.12
CF1-4	15.30	±0.09
CF2-4	10.28	±0.05
CF3-4	6.36	±0.04
CF4-5	5.50	±0.09

manufacturing dimensions and the correctors of the tools (or their positions for none NC machines) and their dimensions (in the case of shape tools).

We propose to name and to represent these correctors and tool dimensions on the manufacturing drawing of the part and of the tools. The correctors are represented by short dimensions drawn on the surface it locates (see Fig. 4). We call them the pilot dimensions because they are the parameters which really enable the steering of the machine by the setter.

For the shape tool making surfaces 3 and 4, the corrector has been placed on surface 4 because it has most dimensions (Fig. 4).

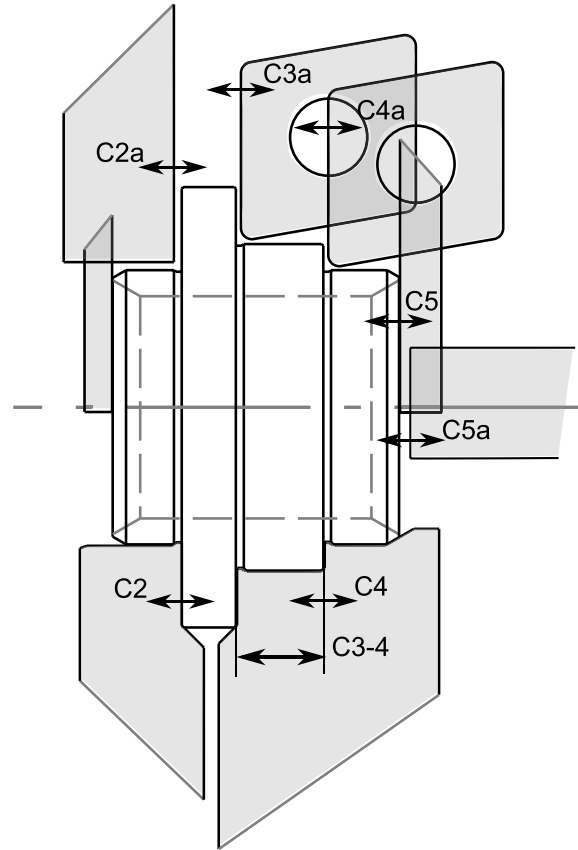

Fig. 4. Representation of the pilot dimensions.

The sawing off tool is positioned near the spindle and is never modified. This is why this tool has not any corrector.

It is quite easy to determine the relationships between the deviations of the manufacturing dimensions and the deviations in position of the tools and of the tool dimensions.

For instance a positive deviation of CF2-4, from its target value, can be due to a deviation in position on the left of the tool making surface 2 and/or to a deviation towards the right of the tool making surface 4. By taking into account the positive displacement direction of the tools, it corresponds to negative deviation of C2 and to a positive deviation of C4.

By doing so, for each manufacturing dimension, we can obtain the entire system of relationships linking the deviations of the manufacturing dimensions and the ones of the pilot dimensions (Eq. (1) in which e_C represents the deviation of dimension C).

$$(1) \quad \begin{cases} e_{CF1-2a} = e_{C2a} \\ e_{CF1-3a} = e_{C3a} \\ e_{CF1-4a} = e_{C4a} \\ e_{CF1-5a} = e_{C5a} \\ e_{CF1-4} = e_{C4} \\ e_{CF2-4} = e_{C4} - e_{C2} \\ e_{CF3-4} = e_{C34} \\ e_{CF4-5} = e_{C5} - e_{C4} \end{cases}$$

Table 2. Measured deviations on the manufacturing dimensions.

	Measured deviation	Tolerance
e_{CF1-2a}	-0.12	± 0.06
e_{CF1-3a}	0.17	± 0.07
e_{CF1-4a}	-0.07	± 0.11
e_{CF1-5a}	-0.20	± 0.12
e_{CF1-4}	0.15	± 0.09
e_{CF2-4}	-0.08	± 0.05
e_{CF3-4}	-0.02	± 0.04
e_{CF4-5}	0.12	± 0.09

The inversion of this system enables us to calculate the deviation of the pilot dimensions in function of the deviations recorded on the manufacturing dimensions (Eq. (2)).

$$(2) \quad \begin{cases} e_{C2a} = e_{CF1-2a} \\ e_{C3a} = e_{CF1-3a} \\ e_{C4a} = e_{CF1-4a} \\ e_{C5a} = e_{CF1-5a} \\ e_{C4} = e_{CF1-4} \\ e_{C2} = e_{CF1-4} - e_{CF2-4} \\ e_{C34} = e_{CF3-4} \\ e_{C5} = e_{CF1-4} + e_{CF4-5}. \end{cases}$$

The corrections needed to be done to the pilot dimensions are the opposite of the calculated deviations. One can find in [7] a general discussion on the inversion of the relationships between the manufacturing dimensions and the correctors.

4 Copilot Pro[®] experimentation on the industrial part

Following the previous determined setup plan, the setter performs partially a first workpiece in order to measure the manufacturing dimensions of the first measuring step. Then he performs completely a second workpiece in order to measure the manufacturing dimensions of the second measuring step (Tab. 2).

The predefined relationships between the pilot dimensions and the manufacturing dimensions (Eq. (2)) enables him to calculate the correction that needs to be done to the correctors and to the tool dimensions (Tab. 3).

By adjusting the tools with the calculated values (except for the tool dimension C34 because it would have required the sharpening of the shape tool) the deviations of the manufacturing dimensions have been cancelled (except for CF3-4 and at the machining and measurement dispersion near). The third workpiece is then conform with the design dimensions.

Table 3. Theoretical corrections to the correctors and to the tool dimension.

	Correction
C2a	0.12
C3a	-0.17
C4a	0.07
C5a	0.20
C2	-0.23
C34	0.02
C4	-0.15
C5	-0.27

5 Conclusion

Thanks to the Copilot Pro[®] method, the setter has been able to setup all the roughing and finishing tools with only two workpieces instead of more than ten. This is achieved by saving material consumption but above all, time for setup and consequently productivity.

In the same way as for the setup plan presented in this paper, a monitoring plan is also given to the setter. This plan is used to measure the workpieces without any interruption of the production. It enables the setter to adjust essentially the finishing tools. For the industrial part presented in this paper, only the finished surfaces are finally measurable. The setter will then only measure the manufacturing dimensions of the second measuring step, on the last or the last few parts produced.

Depending on the wear speed of the roughing tools, the setter will have to regularly use the setup plan presented in this paper to check the setup of the roughing tools.

6 Outlooks

The CTDEC is developing the Copilot Pro Supervisor[®]. It is software able to communicate with different measurement equipment and with most of the Numerical Control of machines. By acquiring automatically the manufacturing dimension values, and knowing the relations linking the deviations of the manufacturing dimensions do the pilot dimensions (Eq. (2)), the software allows the recording of the deviations of the manufacturing dimensions and the sending of the corrections to the Numerical Control of the machine.

The Copilot Pro Method[®], useful for the preparation of the production, will soon be developed on the basis of an already existing prototype.

In addition, the next research works will have for objectives to determine the limits that need to be set on the manufacturing dimensions and the pilot dimensions and under which adjustments should not be made.

Acknowledgements. Copilot Pro[®] is the product of research undertaken by the laboratory Symme of the University of Savoy and by the Technical Center of Industries of Screw-machining (CTDEC) and thanks to the financial support of the Haute-Savoie council, the Rhone-Alps district council and the competitiveness Pole "Arves-Industries Haute-Savoie Mont-Blanc".

References

1. E. Goldschmidt, Gammes et cotation pour le réglage des machines-outils de décolletage, Doctoral thesis, Université de Savoie, France, 2009
2. O.R. Wade, *Tolerance Control in Design and Manufacturing* (Industrial Press, New York, 1967)
3. O.R. Wade, Tolerance control, in: *Tool and manufacturing engineering handbook*, machining (Dearborn, MI, Society of Manufacturing Engineers, 2/1-2/60, 1983), Vol. **1**
4. P. Bourdet, Chaînes de cotes de fabrication (méthode des Delta L) : Première partie, le modèle, L'Ingénieur et Technicien de l'Enseignement Technique **180**, 23-32 (1967)
5. P. Bourdet, Chaînes de cotes de fabrication (méthode des Delta L) : Deuxième partie, le mode opératoire, L'Ingénieur et Technicien de l'Enseignement Technique **191**, 15-23 (1975)
6. E. Pairel, E. Goldchmidt, P.-A. Adragna, P. Hernandez, M. Pillet, The pilot dimensions method: Reconciling Steering and Conformity in Workshops, *International Journal of Production Research*, iFirst, 1-14 (2010)
7. D. Duret, M. Pillet, A. Sergent, Cotation de fabrication paramétrée, Modélisation et pilotage d'une production, *Proceedings of the 3ème Colloque International Conception et Production Intégrées* (CPI'2003) Meknès, Maroc